

Silicon Mesa Rectifiers

Features

- Glass passivated junction
- Hermetically sealed package
- Low reverse current
- High surge current loading

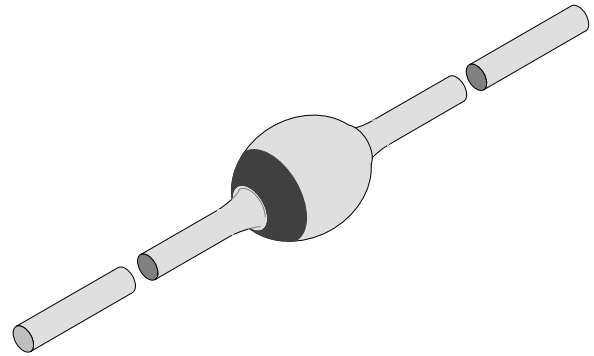

94 9539

Applications

Rectifier, general purpose

Absolute Maximum Ratings

$T_j = 25^\circ\text{C}$

Parameter	Test Conditions	Type	Symbol	Value	Unit
Reverse voltage, repetitive peak reverse voltage		BYX82	$V_R = V_{RRM}$	200	V
		BYX83	$V_R = V_{RRM}$	400	V
		BYX84	$V_R = V_{RRM}$	600	V
		BYX85	$V_R = V_{RRM}$	800	V
		BYX86	$V_R = V_{RRM}$	1000	V
Peak forward surge current	$t_p = 10\text{ms}$		I_{FSM}	50	A
Repetitive peak forward current			I_{FRM}	10	A
Average forward current	$T_{amb} \leq 45^\circ\text{C}$		I_{FAV}	2	A
i^2*t -rating			i^2*t	8	A^2*s
Junction temperature			T_j	175	$^\circ\text{C}$
Storage temperature range			T_{stg}	-65...+175	$^\circ\text{C}$

Maximum Thermal Resistance

$T_j = 25^\circ\text{C}$

Parameter	Test Conditions	Symbol	Value	Unit
Junction ambient	$l = 10\text{mm}, T_L = \text{constant}$	R_{thJA}	45	K/W
	on PC board with spacing 25 mm	R_{thJA}	100	K/W

Characteristics

$T_j = 25^\circ\text{C}$

Parameter	Test Conditions	Type	Symbol	Min	Typ	Max	Unit
Forward voltage	$I_F=1\text{A}$		V_F		0.9	1.0	V
Reverse current	$V_R=V_{RRM}$		I_R		0.1	1	μA
	$V_R=V_{RRM}, T_j=100^\circ\text{C}$		I_R		10	25	μA
Diode capacitance	$V_R=4\text{V}, f=0.47\text{MHz}$		C_D		20		pF
Reverse recovery time	$I_F=0.5\text{A}, I_R=1\text{A}, i_R=0.25\text{A}$		t_{rr}		2	4	μs
Reverse recovery charge	$I_F=I_R=1\text{A}, di/dt=5\text{A}/\mu\text{s}$		Q_{rr}		3	6	μC

Typical Characteristics ($T_j = 25^\circ\text{C}$ unless otherwise specified)

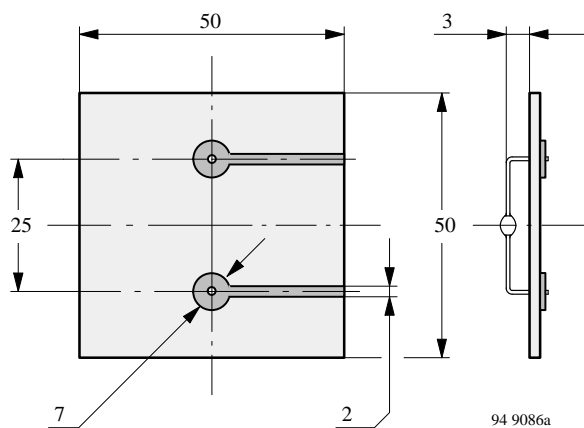

Figure 1 : Epoxy glass hard tissue, board thickness 1.5 mm,
 $R_{thJA} \leq 100 \text{ K/W}$

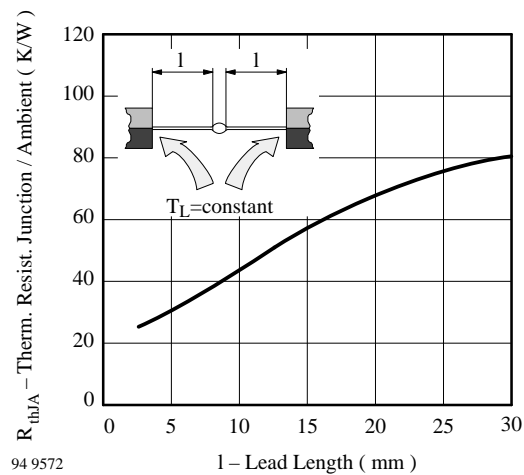
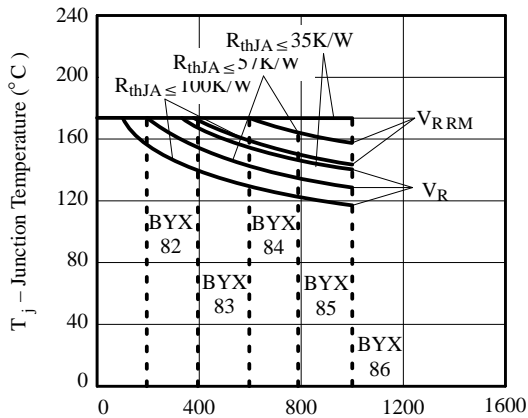
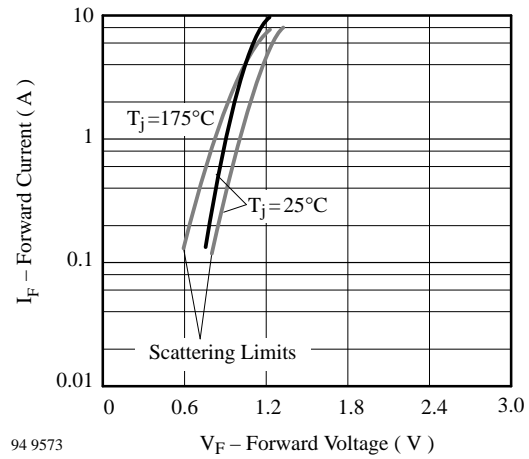

Figure 2 : Thermal Resistance vs. Lead Length



94 9579 V_R, V_{RRM} – Reverse / Repetitive Peak Reverse Voltage

Figure 3 : Junction Temperature vs. Reverse/Repetitive Peak Reverse Voltage



94 9573

Figure 4 : Forward Current vs. Forward Voltage

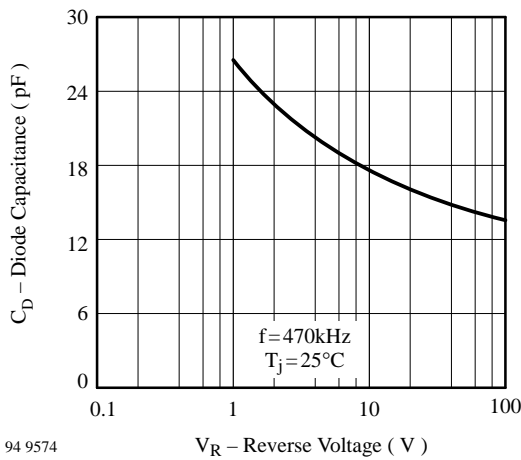

94 9574

Figure 5 : Diode Capacitance vs. Reverse Voltage

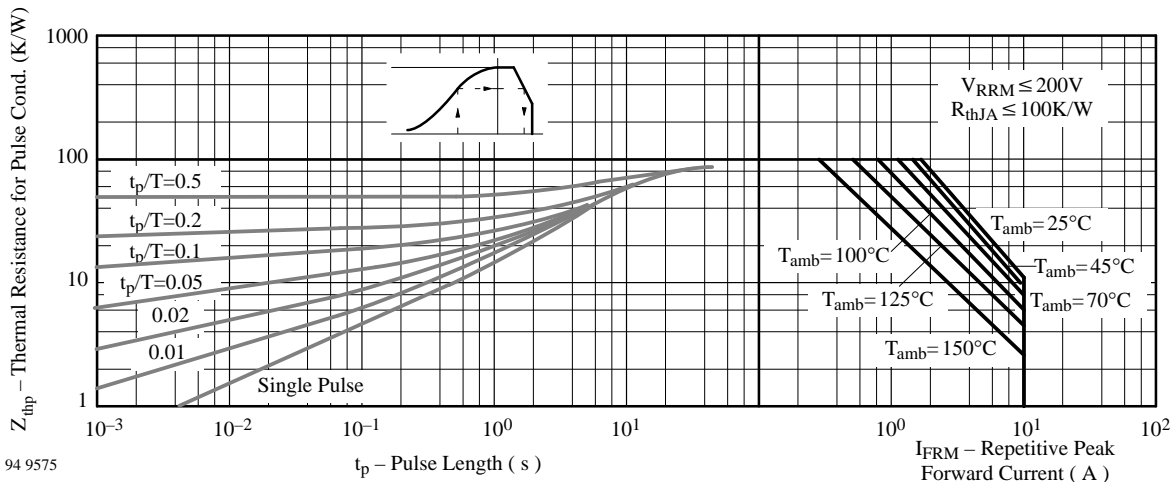

94 9575

Figure 6 : Thermal Response

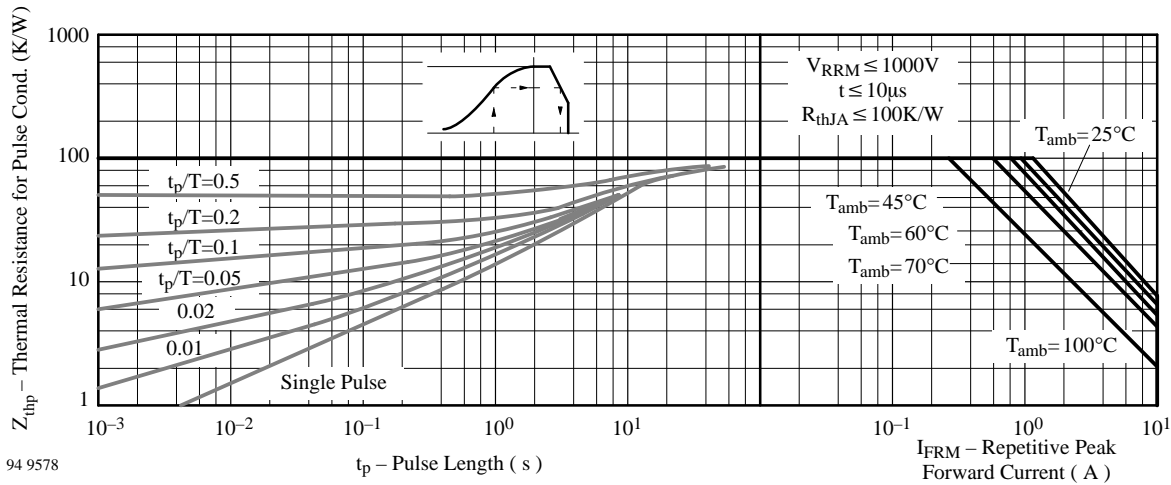

94 9578

Figure 7 : Thermal Response

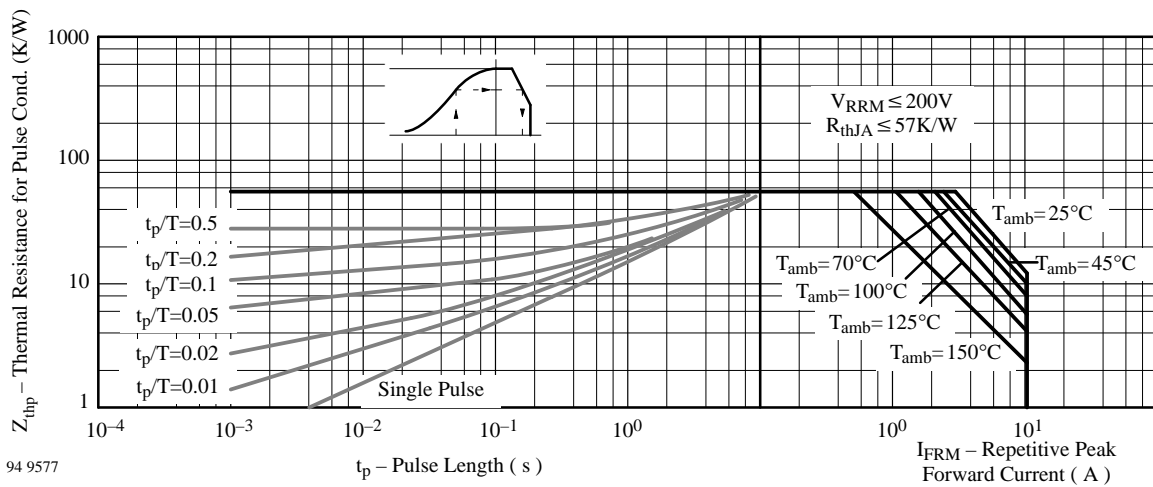

94 9577

Figure 8 : Thermal Response

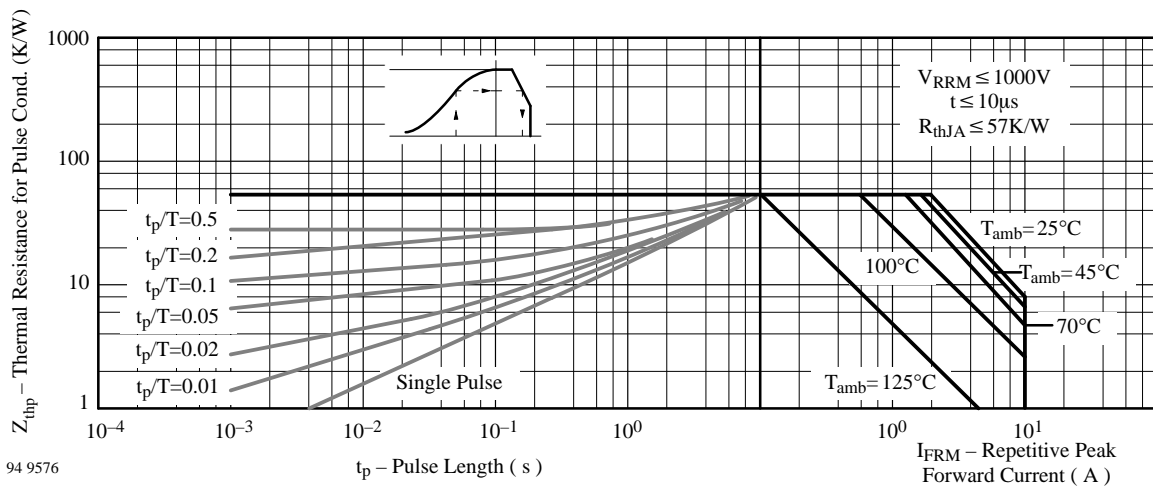

94 9576

Figure 9 : Thermal Response

Dimensions in mm

Sintered Glass Case
SOD 57
Weight max. 0.5 g

technical drawings
according to DIN
specifications

94 9538

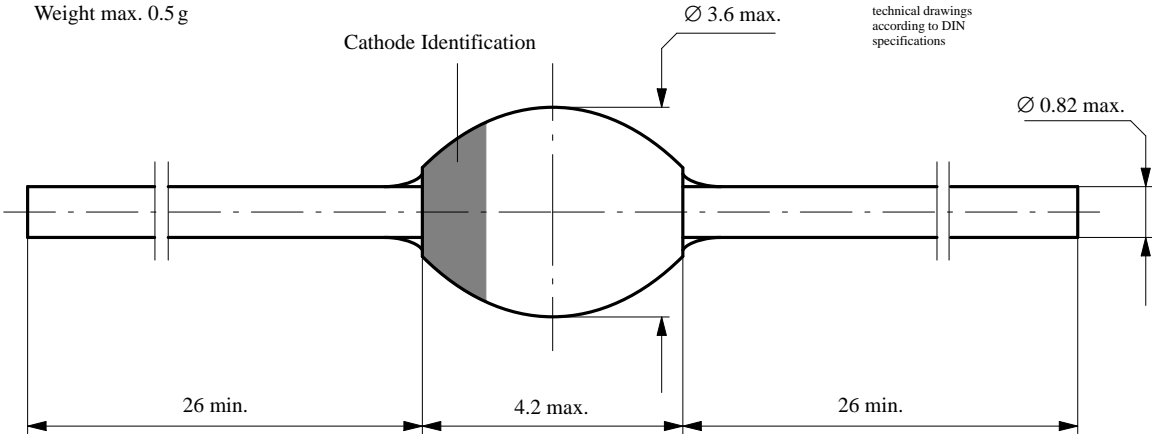

OZONE DEPLETING SUBSTANCES POLICY STATEMENT

It is the policy of **TEMIC TELEFUNKEN microelectronic GmbH** to

1. Meet all present and future national and international statutory requirements and
2. Regularly and continuously improve the performance of our products, processes, distribution and operating systems with respect to their impact on the health and safety of our employees and the public, as well as their impact on the environment.

Of particular concern is the control or elimination of releases into the atmosphere of those substances which are known as ozone depleting substances (ODSs).

The Montreal Protocol (1987) and its London Amendments (1990) will soon severely restrict the use of ODSs and forbid their use within the next ten years. Various national and international initiatives are pressing for an earlier ban on these substances.

TEMIC TELEFUNKEN microelectronic GmbH semiconductor division has been able to use its policy of continuous improvements to eliminate the use of any ODSs listed in the following documents.

1. Annex A, B and list of transitional substances of the Montreal Protocol and the London Amendments respectively
2. Class I and II ozone depleting substances in the Clean Air Act Amendments of 1990 by the Environmental Protection Agency (EPA) in the USA and
3. Council Decision 88/540/EEC and 91/690/EEC Annex A, B and C (transitional substances) respectively.

TEMIC can certify that our semiconductors are not manufactured with and do not contain ozone depleting substances.

We reserve the right to make changes to improve technical design without further notice.

Parameters can vary in different applications. All operating parameters must be validated for each customer application by the customer. Should the buyer use TEMIC products for any unintended or unauthorized application, the buyer shall indemnify TEMIC against all claims, costs, damages, and expenses, arising out of, directly or indirectly, any claim of personal damage, injury or death associated with such unintended or unauthorized use.

TEMIC TELEFUNKEN microelectronic GmbH, P.O.B. 3535, D-74025 Heilbronn, Germany
Telephone: 49 (0)7131 67 2831, Fax Number: 49 (0)7131 67 2423